

# Slow Poke™

## Sport 40 ARF

### INSTRUCTION MANUAL

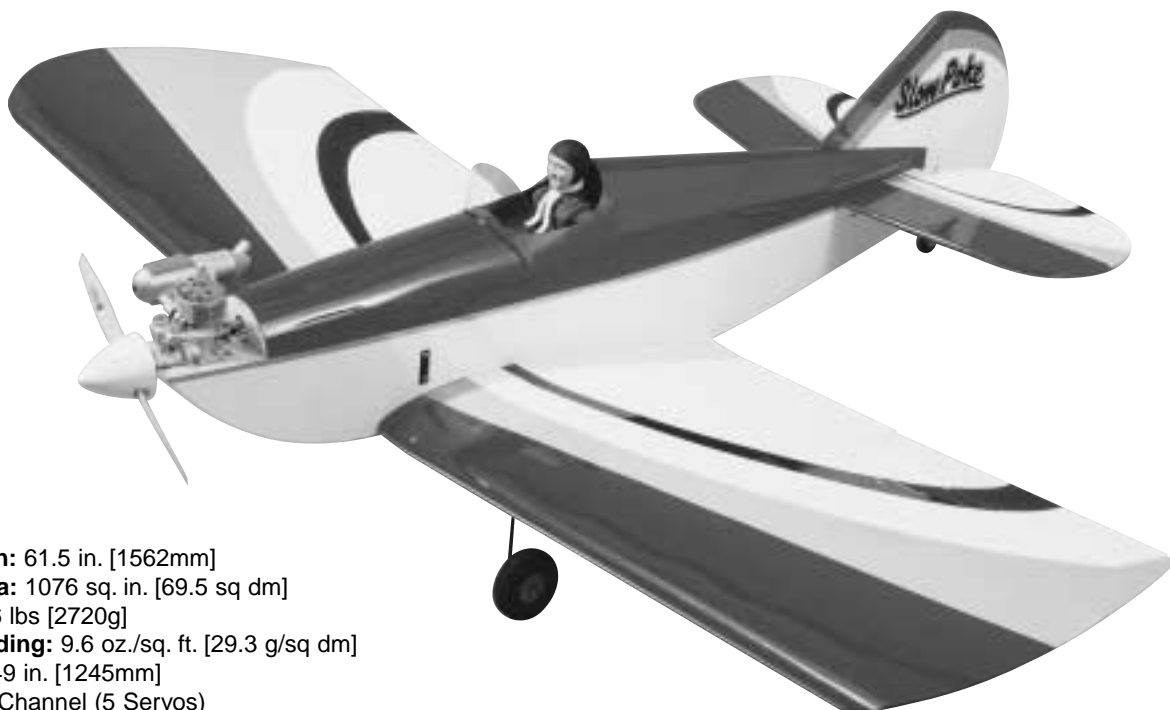

**Wingspan:** 61.5 in. [1562mm]

**Wing area:** 1076 sq. in. [69.5 sq dm]

**Weight:** 6 lbs [2720g]

**Wing loading:** 9.6 oz./sq. ft. [29.3 g/sq dm]

**Length:** 49 in. [1245mm]

**Radio:** 4-Channel (5 Servos)

**Engine:** .35 to .46 two-stroke, .52 four-stroke [5.75 to 7.5cc two-stroke, 8.5cc four-stroke]

#### WARRANTY

**Great Planes® Model Manufacturing Co.** guarantees this kit to be free from defects in both material and workmanship at the date of purchase. This warranty does not cover any component parts damaged by use or modification. **In no case shall Great Planes' liability exceed the original cost of the purchased kit.** Further, Great Planes reserves the right to change or modify this warranty without notice.

In that Great Planes has no control over the final assembly or material used for final assembly, no liability shall be assumed nor accepted for any damage resulting from the use by the user of the final user-assembled product. By the act of using the user-assembled product, the user accepts all resulting liability.

**If the buyer is not prepared to accept the liability associated with the use of this product, the buyer is advised to return this kit immediately in new and unused condition to the place of purchase.**

**READ THROUGH THIS MANUAL BEFORE STARTING CONSTRUCTION. IT CONTAINS IMPORTANT WARNINGS AND INSTRUCTIONS CONCERNING THE ASSEMBLY AND USE OF THIS MODEL.**



1610 Interstate Drive Champaign, IL 61822

(217) 398-8970, Ext 2

airsupport@greatplanes.com

## TABLE OF CONTENTS

<b>INTRODUCTION</b> .....	<b>2</b>
<b>SAFETY PRECAUTIONS</b> .....	<b>2</b>
<b>DECISIONS YOU MUST MAKE</b> .....	<b>3</b>
Radio Equipment .....	3
Engine Recommendations .....	3
<b>ADDITIONAL ITEMS REQUIRED</b> .....	<b>3</b>
Hardware and Accessories .....	3
Covering Accessories .....	3
Adhesives and Building Supplies .....	3
Optional Supplies and Tools .....	3
<b>IMPORTANT BUILDING NOTES</b> .....	<b>4</b>
<b>ORDERING REPLACEMENT PARTS</b> .....	<b>4</b>
<b>KIT CONTENTS</b> .....	<b>5</b>
<b>METRIC CONVERSION RULER</b> .....	<b>5</b>
<b>BUILDING INSTRUCTIONS</b> .....	<b>6</b>
Wing Assembly .....	6
Install the Ailerons .....	8
Install the Aileron Servos .....	8
Install the Main Landing Gear .....	10
Mount the Stab and Fin .....	11
Mount the Engine and Fuel Tank .....	13
Install the Radio .....	15
<b>FINAL ASSEMBLY</b> .....	<b>17</b>
Control Throw Adjustment .....	17
Control Surface Throws .....	17
<b>BALANCE YOUR MODEL</b> .....	<b>18</b>
Balance the Model Laterally .....	18
<b>PREFLIGHT</b> .....	<b>18</b>
Charge the Batteries .....	18
Balance the Propeller .....	18
Find a Safe place to Fly .....	19
Ground Check your Model .....	19
Range Check your Radio .....	19
<b>ENGINE SAFETY PRECAUTIONS</b> .....	<b>19</b>
<b>AMA SAFETY CODE</b> .....	<b>20</b>
General .....	20
Radio Control .....	20
<b>FLYING</b> .....	<b>20</b>
Takeoff .....	20
Flight .....	20
Landing .....	20

## INTRODUCTION

The Slow Poke Sport .40 ARF is a great follow up to our Slow Poke Sport .40 kit but you don't have to do the building! This plane has all of the great flight characteristics of a sport / fun fly airplane. This coupled with its good looks will make it a standout at your flying field. With minimal effort you will have this plane in the air in no time and performing to all of your abilities. We hope you enjoy the Slow Poke Sport .40 ARF as much as we have enjoyed bringing it to you!

For the latest technical updates or manual corrections for the Slow Poke Sport .40 ARF, visit the web site listed below and select the Great Planes Slow Poke Sport .40 ARF. A "tech notice" box will appear in the upper left corner of the page if there is new technical information or changes to this kit.

<http://www.greatplanes.com/airplanes/index.html>

### **PROTECT YOUR MODEL, YOURSELF & OTHERS...FOLLOW THESE IMPORTANT SAFETY PRECAUTIONS**

1. Your Slow Poke Sport .40 ARF should not be considered a toy, but rather a sophisticated, working model that functions very much like a full-size airplane. Because of its performance capabilities, the Slow Poke Sport .40, if not assembled and operated correctly, could possibly cause injury to yourself or spectators and damage to property.
2. You must assemble the model **according to the instructions**. Do not alter or modify the model, as doing so may result in an unsafe or unflyable model. In a few cases the instructions may differ slightly from the photos. In those instances the written instructions should be considered as correct.
3. You must take time to **build straight, true and strong**.
4. You must use an R/C radio system that is in first-class condition and a correctly sized engine and components (fuel tank, wheels, etc.) throughout the building process.
5. You must correctly install all R/C and other components so that the model operates correctly on the ground and in the air.
6. You must check the operation of the model before every flight to insure that all equipment is operating and that the model has remained structurally sound. Be sure to check clevises or other connectors often and replace them if they show any signs of wear or fatigue.
7. If you are not already an experienced R/C pilot, you should fly the model only with the help of a competent, experienced R/C pilot.

We, as the kit manufacturer, provide you with a top quality kit and instructions, but ultimately the quality and flyability of your finished model depends on how you build it; therefore, we cannot in any way guarantee the performance of your completed model and no representations are expressed or implied as to the performance or safety of your completed model.

**Remember: Take your time and follow the instructions to end up with a well-built model that is straight and true.**

If you have not flown this type of model before, we recommend that you get the assistance of an experienced pilot in your R/C club for your first flights. If you're not a member of a club, your local hobby shop has information about clubs in your area whose membership includes experienced pilots.

In addition to joining an R/C club, we strongly recommend you join the AMA (Academy of Model Aeronautics). AMA membership is required to fly at AMA sanctioned clubs. There are over 2,500 AMA chartered clubs across the country. Among other benefits, the AMA provides insurance to its members who fly at sanctioned sites and events. Additionally, training programs and instructors are available at AMA club sites to help you get started the right way. Contact the AMA at the address or toll-free phone number below:



**Academy of Model Aeronautics**  
5151 East Memorial Drive  
Muncie, IN 47302-9252  
Tele. (800) 435-9262  
Fax (765) 741-0057

Or via the Internet at: <http://www.modelaircraft.org>

## DECISIONS YOU MUST MAKE

This is a partial list of items required to finish the Slow Poke Sport .40 ARF that may require planning or decision making before starting to build. Order numbers are provided in parentheses.

### Radio Equipment

The Slow Poke Sport .40 ARF will require a good 4-channel radio such as the Futaba® 4VF with five servos (minimum of 40 oz/in of torque), a Y-harness and two 6" [152mm] servo extensions.

### Engine Recommendations

The recommended engine size range for the Slow Poke Sport .40 ARF is .35 to .46 two-stroke or .52 four-stroke.

## ADDITIONAL ITEMS REQUIRED

### Hardware and Accessories

In addition to the items listed in the "Decisions You Must Make" section, the following is the list of hardware and accessories required to finish the Slow Poke Sport .40 ARF. Order numbers are provided in parentheses.

- Propellers - Top Flite® Power Point® - refer to engine's instruction manual for proper size.
- Fuel line - 3' medium 3/32" [2.4mm] glow fuel tubing (GPMQ4131)

### Covering Accessories

- 21st Century® sealing iron (COVR2700)
- 21st Century trim seal iron (COVR2750)
- 21st Century iron cover (CORQ2702)

### Adhesives and Building Supplies

In addition to common household tools and hobby tools, this is the "short list" of the most important items required to build the Slow Poke Sport .40 ARF. **Great Planes Pro™ CA and Epoxy glue are recommended.**

- 1/2 oz. Thin Pro CA (GPMR6001)
- 1/2 oz. Medium Pro CA+ (GPMR6007)
- 6-Minute Epoxy (GPMR6045)
- Hobby knife (HCAR0105)
- #11 blades (HCAR0211)
- Small T-pins (HCAR5100)
- Builder's triangle (HCAR0480)
- Electric drill and 1/16" [1.6mm] drill bit
- Small Phillips and flat blade screwdrivers
- Pliers with wire cutter (HCAR0630)

### Optional Supplies and Tools

Here is a list of optional tools mentioned in the manual that will help you build the Slow Poke Sport .40 ARF.

- Great Planes CG Machine™ (GPMR2400)
- Top Flite Precision Magnetic Prop Balancer™ (TOPQ5700)
- Straightedge with scale (HCAR0475)
- Cutting mat (HCAR0456)
- Masking Tape (TOPR8018)
- CA Debonder (GPMR6039)
- CA Applicator tips (GPMR6033)
- 1/2 oz. Thin CA (GPMR6002)
- 1/2 oz. Medium CA (GPMR6008)
- CA Applicator Tips (HCAR3780)
- CA Debonder (GPMR6039)
- CA accelerator (GPMR6034)

- 30-Minute Epoxy (GPMR6047)
- R/C-56 Canopy Glue (JOZR5007)
- Epoxy Brushes (GPMR8060)
- Mixing Sticks (GPMR8055)
- Threadlocker (GPMR6060)
- Denatured Alcohol (for epoxy clean up)
- Hobby Knife (HCAR0105), #11 Blades (HCAR0211)
- Non-elastic monofilament or Kevlar fishing line (for stab alignment)
- Builders Triangle Set (HCAR0480) (for fin alignment)
- Masking Tape (TOPR8018)
- 1/16" to 1/4" drill bit set
- Dead Center™ Engine Mount Hole Locator (GPMR8130)
- Great Planes AccuThrow™ Deflection Gauge (for measuring control throws, GPMR2405)

**IMPORTANT BUILDING NOTES**

- There are two types of screws used in this kit:

**Sheet metal screws** are designated by a number and a length. For example #6 x 3/4"



*This is a number six screw that is 3/4" long.*

**Machine screws** are designated by a number, threads per inch and a length. For example 4-40 x 3/4"

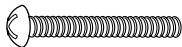

*This is a number four screw that is 3/4" long with forty threads per inch.*

- Whenever the term **glue** is written you should rely upon your experience to decide what type of glue to use. When a specific type of adhesive works best for that step, the instructions will make a recommendation.

- Whenever just **epoxy** is specified you may use **either** 30-minute epoxy **or** 6-minute epoxy. When 30-minute epoxy is specified it is **highly** recommended that you use only 30-minute (or 45-minute) epoxy, because you will need the working time and/or the additional strength.

- **Photos** and **sketches** are placed **before** the step they refer to. Frequently you can study photos in following steps to get another view of the same parts.

- The Slow Poke Sport .40 ARF is factory-covered with Top Flite MonoKote® film. Should repairs ever be required, MonoKote can be patched with additional MonoKote purchased separately. MonoKote is packaged in six-foot rolls, but some hobby shops also sell it by the foot. If only a small piece of MonoKote is needed for a minor patch, perhaps a fellow modeler would give you some. MonoKote is applied with a model airplane covering iron, but in an emergency a regular iron could be used. A roll of MonoKote includes full instructions for application. Following are the colors used on this model and order numbers for six foot rolls.

- White TOPQ0204
- Gray TOPQ0211
- Sapphire Blue TOPQ0226
- Black TOPQ0208

**ORDERING REPLACEMENT PARTS**

To order replacement parts for the Great Planes Slow Poke Sport .40 ARF, use the order numbers in the **Replacement Parts List** that follows. Replacement parts are available only as listed. Not all parts are available separately (an aileron cannot be purchased separately, but is only available with the wing kit). Replacement parts are not available from Product Support, but can be purchased from hobby shops or mail order/Internet order firms. Hardware items (screws, nuts, bolts) are also available from these outlets. If you need assistance locating a dealer to purchase parts, visit [www.greatplanes.com](http://www.greatplanes.com) and click on "Where to Buy." If this kit is missing parts, contact **Great Planes Product Support**.

**Replacement Parts List**

<u>Order Number</u>	<u>Description</u>	<u>How to Purchase</u>
	Missing pieces .....	Contact Product Support
	Instruction manual.....	Contact Product Support
	Full-size plans .....	Not available
GPMA2265.....	Wing Kit	} ..... Contact Your Hobby Supplier to Purchase These Items
GPMA2266.....	Fuse Kit	
GPMA2267.....	Tail Set	
GPMA2268.....	Landing Gear	

# KIT CONTENTS

Before starting to build, use the **Kit Contents** list to take an inventory of your kit to make sure it is complete and inspect the parts to make sure they are of acceptable quality. If any parts are missing or are not of acceptable quality, or if you need assistance with assembly, contact **Great Planes Product Support**. When reporting defective or missing parts, use the part names exactly as they are written in the Kit Contents list on this page.

**Great Planes Product Support:**  
**Phone: (217) 398-8970**  
**Fax: (217) 398-7721**  
**E-mail: [airsupport@greatplanes.com](mailto:airsupport@greatplanes.com)**

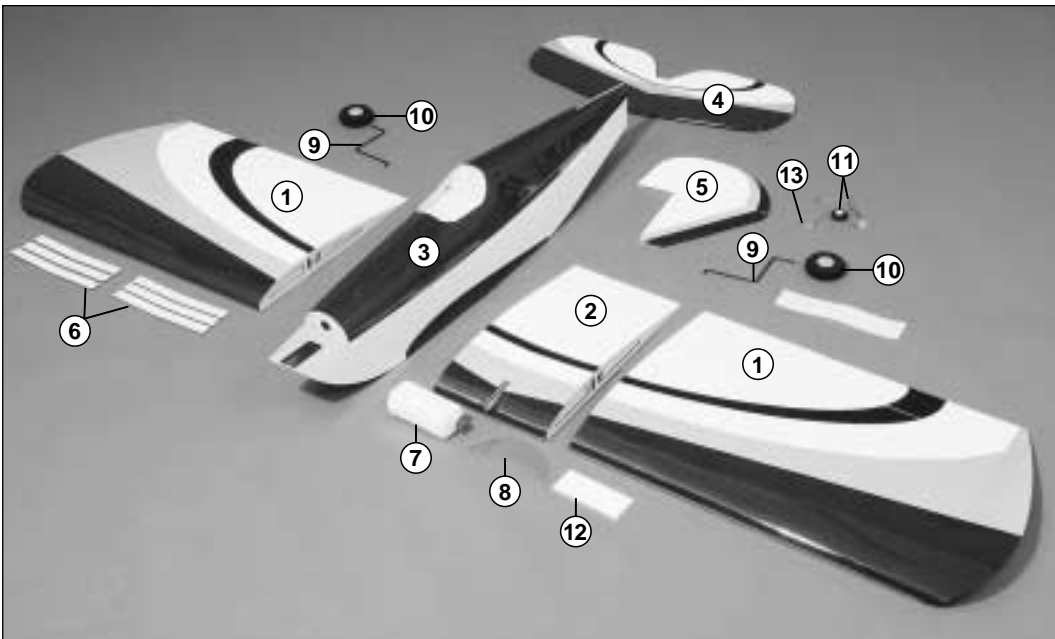

## Kit Contents (Photographed)

- 1 Outer Wings w/ Ailerons
- 2 Wing Center Section
- 3 Fuselage
- 4 Stab and Elevators
- 5 Fin and Rudder
- 6 Plywood Wing Joiners
- 7 Fuel Tank & Hardware
- 8 Windscreen
- 9 Main Landing Gear Wires
- 10 2-3/4" Main Wheels
- 11 Tail Gear with Wheel
- 12 Wing Bolt Plate
- 13 Wing Joiner Wire

## Kit Contents (Not Photographed)

- |   |  |   |
|---|--|---|
| <ul style="list-style-type: none"> <li>(2) 1/4 - 20 Blind Nuts (Pre-installed in fuse)</li> <li>(2) 24" Grey Plastic Outer Pushrod Tubes (Pre-installed in Fuselage)</li> <li>(1) 11-3/4" Grey Plastic Outer Pushrod Tube (Throttle)</li> <li>(2) 12" .074 Wire Threaded One End (Ailerons)</li> <li>(2) 36" .074 Wire Threaded One End (Elevator and Rudder)</li> <li>(1) 17-1/2" .074 Wire Threaded One End (Throttle)</li> <li>(1) 2" x 9" Hinge Material</li> <li>(1) Nylon Clevis (Rudder, Elevator, Ailerons and Throttle)</li> </ul> | <ul style="list-style-type: none"> <li>(4) Faslink (Rudder, Elevator, Ailerons and Throttle)</li> <li>(2) Nylon 1/4 - 20 Wing Bolt (Wing)</li> <li>(4) Large Nylon Control Horn (Aileron, Rudder and Elevator)</li> <li>(1) Nylon Landing Gear Strap (1 tree of 4, Landing Gear)</li> <li>(5) Silicone Clevis Keepers (Rudder, Elevator, Ailerons and Throttle)</li> <li>(4) 6-32 Blind Nuts (Mounting the Engine)</li> <li>(4) 6-32 x 1/2" Socket Head Cap Screws (Mounting the Engine)</li> <li>(4) #6 lock washers (Mounting the Engine)</li> <li>(4) #6 washers (Mounting the Engine)</li> </ul> | <ul style="list-style-type: none"> <li>(4) 5/32" Wheel Collar (Landing Gear)</li> <li>(4) 6-32 Set Screws (Wheel Collars)</li> <li>(1) 3/32" Wheel Collar (Tail Wheel)</li> <li>(1) 4-40 Set Screw (Tail Wheel)</li> <li>(12) #2 x 1/2" Sheet Metal Screws (Aileron Horns, Landing Gear Straps)</li> <li>(4) #2 x 5/8" Machine Screws (Rudder, Elevator)</li> <li>(1) Brass Quick Connect Body (Throttle connection)</li> <li>(1) Nylon Retainer (Throttle connection)</li> <li>(1) 4-40 X 1/2" Socket Head Cap Screw (Throttle connection)</li> <li>(1) White Plastic Spinner</li> </ul> |
|---|--|---|

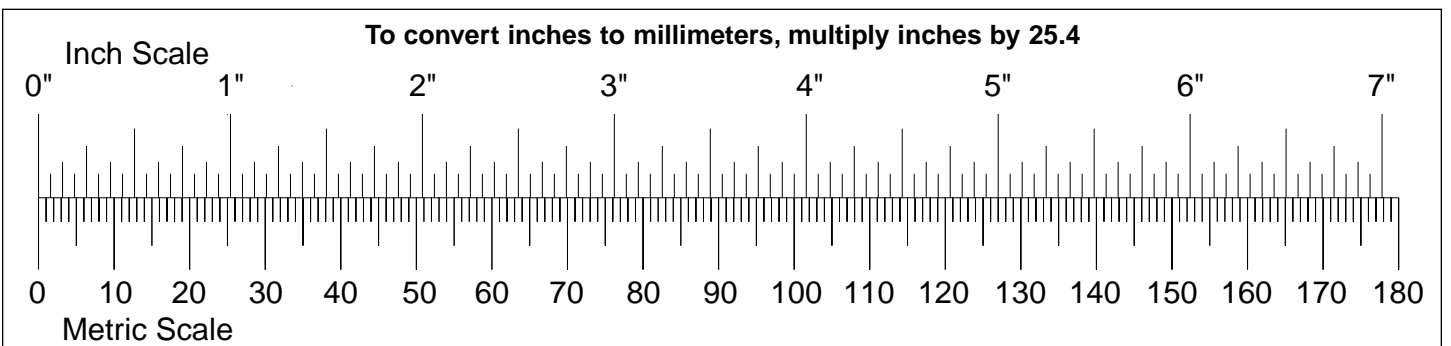

# BUILDING INSTRUCTIONS

## Wing Assembly

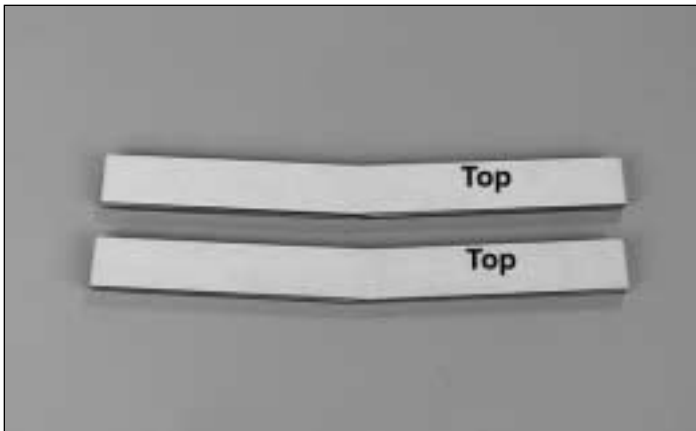

❑ 1. Locate six **wing joiners**. Make two wing joiners by gluing three of the joiners together with 6-minute epoxy. Wipe away any excess epoxy that may squeeze out. Set them aside to allow the glue to cure. After the glue has cured mark the top of the wing joiner as shown.

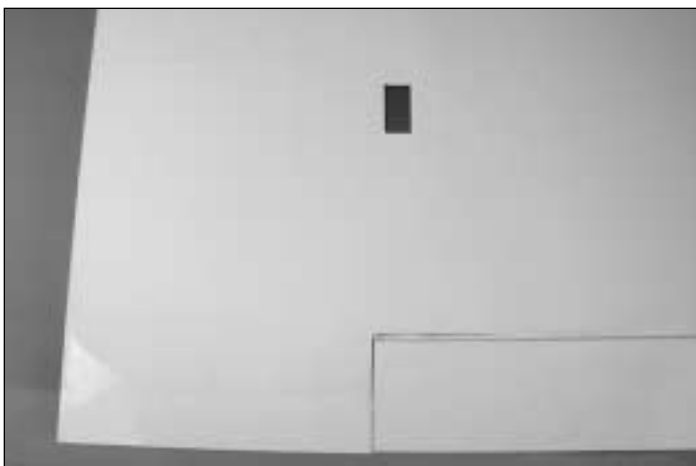

❑ 2. Locate the left and right wing panels. On the bottom of the wing locate the aileron servo compartment. Cut the film away with a hobby knife to reveal the servo compartment. Iron the covering around the opening with a modeling iron.



❑ 3. Locate the slot at the leading edge of the left and right wing for the landing gear. Cut the covering away from the slot and iron any loose covering in place with your hobby iron.

❑ 4. Trial fit the two wing joiners into the **wing center section**, into the **right wing panel** and **left wing panel**. Be sure the wing joiners are inserted so that the top of the joiner is against the top of the wing. When you are satisfied that they fit remove the wings from the wing joiners.

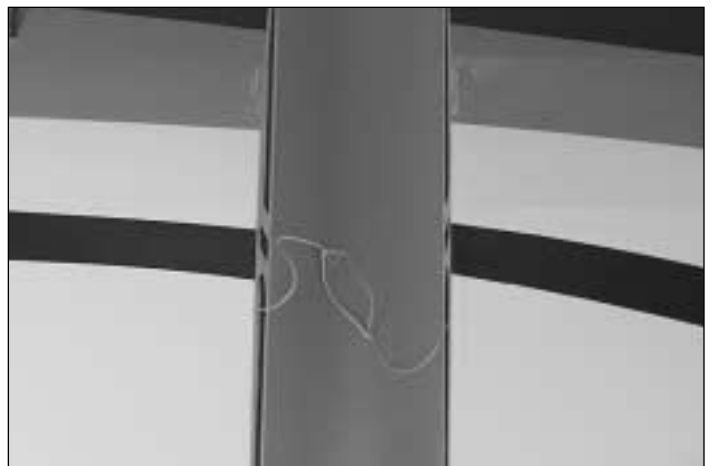

❑ 5. The wing center section and outboard wings have string taped to the root rib. Set the wing joiner and the right wing panel side by side. Tie the two strings together. These strings will be used to pull the servo wires through the wing when you install the radio system.



6. Mix 4 oz. of 30-minute epoxy in a mixing cup. Apply a liberal amount of epoxy into the wing joiner box in the wing and the wing center section. Apply epoxy to the root rib of the wing and the wing center section. Finally, apply epoxy to both sides, the top and the bottom of the wing joiner. Insert the joiner into the wing center section. Slide the right wing panel onto the joiner. Wipe any excess epoxy from the wing joint and clean any glue residue with rubbing alcohol. Hold the wing and the wing center section together with masking tape. Set the assembly aside until the glue has cured. Once cured repeat steps 5 and 6 for the left wing panel.

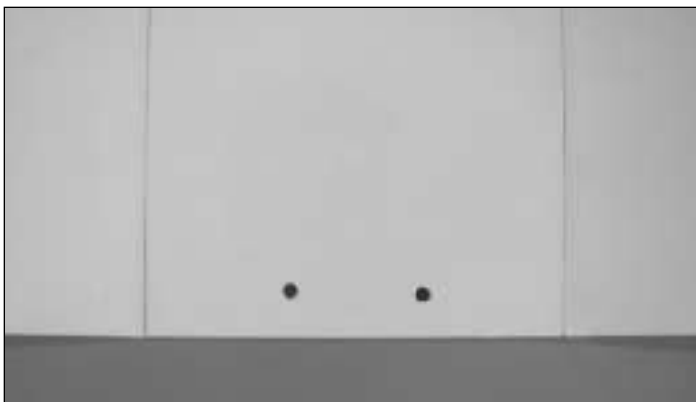

7. On the top of the wing locate the two 1/4" [6mm] holes in the wing center section at the trailing edge of the wing. Cut away the covering material where these holes are located.

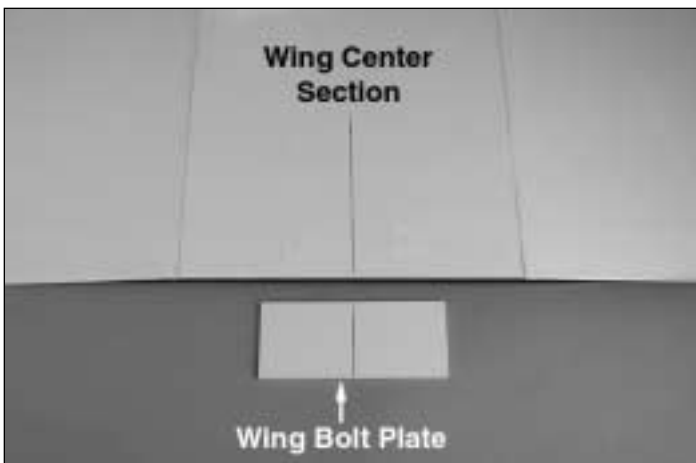

8. Locate the 2" x 4-1/2" [51 x 115mm] plywood **wing bolt plate**. Draw a line on the center of the plate across the

2" width of the plate. On the bottom of the wing center section, locate the center of the wing center section and draw a line 3" long marking the center of the wing.

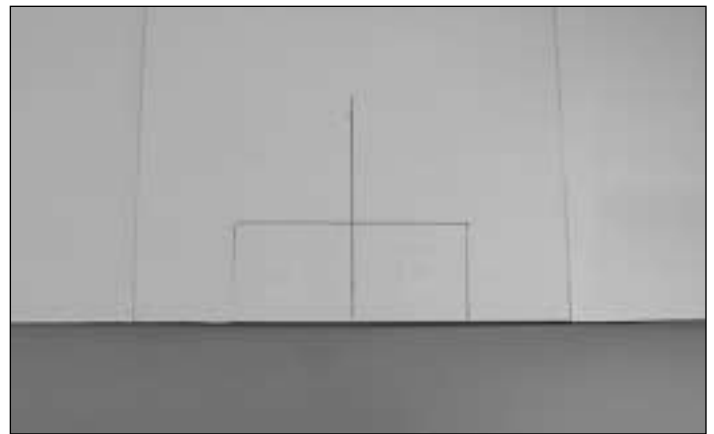

9. Place the plywood wing bolt plate on the bottom of the wing center section at the trailing edge of the wing, aligning the lines that you drew on the wing and the wing bolt plate. Trace the plywood landing gear plate onto the center of the wing with a marker. Cut away the covering inside of the lines you have just traced onto the wing, being careful not to cut into the wing sheeting.

10. Using 6-minute epoxy, glue the plywood wing bolt plate to the wing center section in the area where you have removed the covering.



11. Turn the wing over so that you are looking at the top of the wing. Use a 17/64" [6.7mm] drill bit to drill through the wing bolt holes into and through the landing gear plate.

## Install the Ailerons

❑ 1. The **ailerons** are taped in place to the wing. Remove them from the wing.

❑ 2. Begin with the right aileron. On the leading edge of the aileron you will find three hinge slots pre-cut into it. You will also find three hinge slots cut into wing trailing edge. Insert your hobby knife into the hinge slots to be sure there is enough clearance for the hinges.

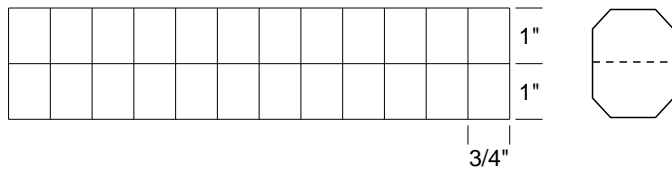

❑ 3. Locate the 2" x 9" [51 x 229mm] **hinge material**. Cut fifteen 1" x 3/4" [25 x 19mm] hinges from the strip as shown in the above sketch. Clip the corners of each one as shown. This will allow easier installation of the hinges.

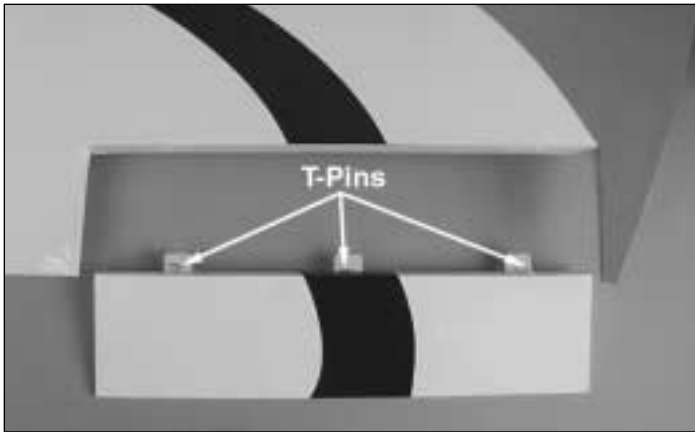

❑ 4. Insert a T-pin into the center of three hinges. This will assure that the hinge material remains centered between the aileron and the wing. Install the hinges into the three hinge slots in the leading edge of the aileron.



❑ 5. Once the hinges are fit to the aileron, insert the opposite end of the hinges into the trailing edge of the wing. Make sure that the aileron is centered in the aileron opening in the wing. Remove the T-pins.

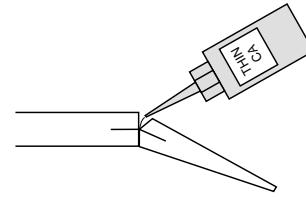

❑ 6. Apply 6 drops of thin CA to the top and bottom of each of the hinges. Allow the glue to cure and do not use any type of CA accelerator to speed up the curing process as this will make the hinge brittle.

❑ 7. Repeat these steps for the left wing and aileron.

## Install the Aileron Servos

❑ 1. The installation of the aileron servos requires two 6" servo extensions. The extensions must be compatible with your radio system and must be purchased separately. Plug the 6" extension to the servo. Secure the connection with tape to assure that the connectors do not accidentally come unplugged.



❑ 2. On the bottom of the right wing in the servo opening there is a piece of string taped to the rib. Remove the string from the rib. Tie the string to the end of the servo wires.



❑ 3. Pull the servo lead through the wing. Tape the end of the servo lead to the center section of the wing to prevent it from accidentally falling back into the wing. You may wish to trim away the excess covering material from the hole where the servo lead exits the wing.



❑ ❑ 4. Install the aileron servo into the servo bay using the hardware supplied by the radio manufacturer. Drill a 1/16" [1.6mm] pilot hole through each of the servo mounting holes. This will prevent the hardwood blocks from splitting when you install the screws.



❑ ❑ 5. Temporarily plug your aileron servo into the receiver. Turn the radio system on and allow the servo to center itself. With the servo centered install a medium length servo arm onto the servo so that the arm is on the left side of the servo as shown in the photograph. (The arm will be on the right side of the servo for the installation of the servo in the opposite wing.)

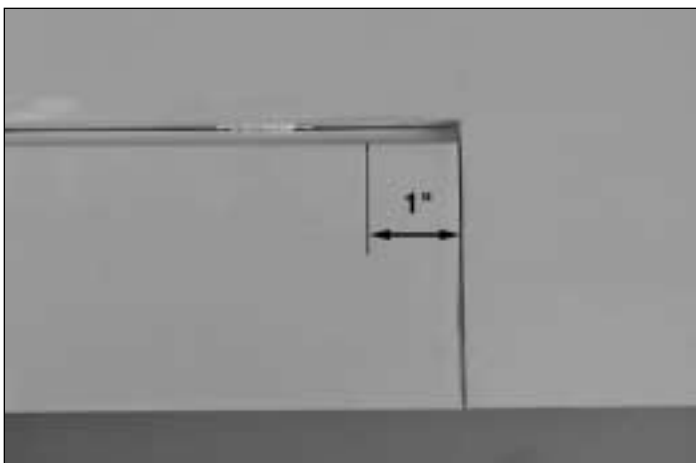

❑ ❑ 6. From the inboard end of the aileron measure in 1" [25mm]. Draw a line on that mark across the aileron as shown.

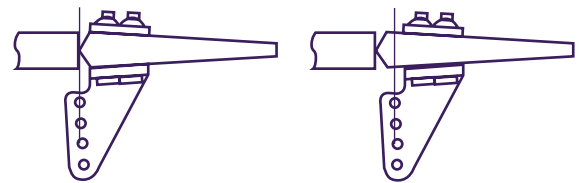
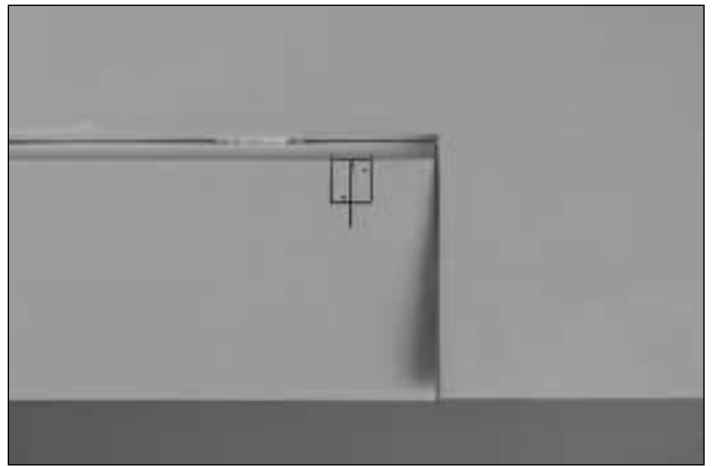

Correct

Incorrect

❑ ❑ 7. Locate one of the **nylon control horns**. Separate the horn and the screw mounting plate. (You can discard the screw mounting plate.) Place the control horn on the aileron, aligning the center of the horn on the line that you have drawn. Position the horn at the leading edge of the aileron as shown in the sketch. Trace the outline of the control horn onto the aileron and mark the location of the mounting holes.

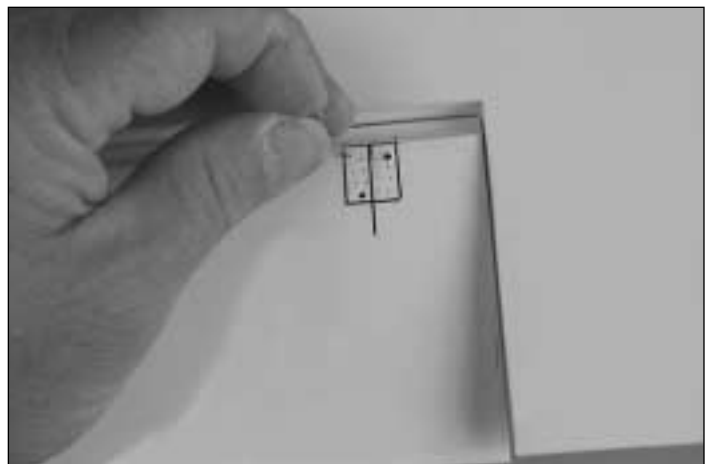

❑ ❑ 8. Drill a 1/6" [1.6mm] hole 3/8" [9.5mm] deep on both of the mounting hole locations. Using a T-pin, poke small holes through the iron-on covering, piercing the wood under the covering.

❑ ❑ 9. **IMPORTANT: Do not omit this step!** Using thin CA saturate the small pin holes and the holes you drilled for the mounting screws. Allow the CA to cure. Install a #2 x 3/8" [#2 x 9.5mm] sheet metal screw into each of the mounting holes. Remove the screw and put a couple of drops of thin CA into the screw holes and allow the CA to cure.

□ □ 10. Mount the control horn to the aileron with two #2 x 3/8" [#2 x 9.5mm] sheet metal screws.

□ □ 11. Locate a .074 x 12" **pushrod wire** threaded on one end. Screw a nylon clevis onto the threaded end of the wire 25 turns. Install a silicone clevis keeper onto the clevis. Install the clevis on the aileron control horn.

□ □ 12. Be sure the aileron servo is centered (plug the servo into the receiver and turn the radio on to re-center it properly if you are unsure). Center the aileron and align the wire pushrod with the hole in the end of the servo arm. Using a marker, mark the location where the wire aligns with the hole in the servo arm. On that mark make a 90 degree bend. From the bend measure up 3/8" [9.5mm]. Cut off the excess pushrod wire.

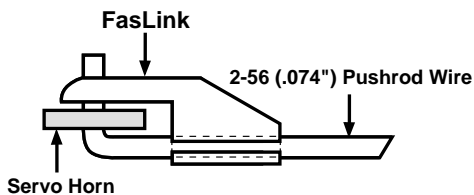

□ □ 13. Install the wire into the hole in the servo arm using a nylon **FasLink** as shown in the sketch.

□ □ 14. Repeat these steps for the servo installation in the left wing.

□ 15. Having separate servos on each aileron could be new to some modelers. When connecting two separate servos to a single channel on your radio you will either need to plug them into a Y-harness or if your radio has the capability of mixing two separate channels to the aileron you can connect the servos that way. Review your radio instruction manual to see if it has this capability. If you are going to be using a Y-harness plug the servos into the connector. Tape the servo leads to the connector to prevent them from coming unplugged.

## Install the Main Landing Gear

□ □ 1. Locate the wire **landing gear**. Both of them are the same so there is no left or right. Install the wire into the slot in the bottom of the right wing.

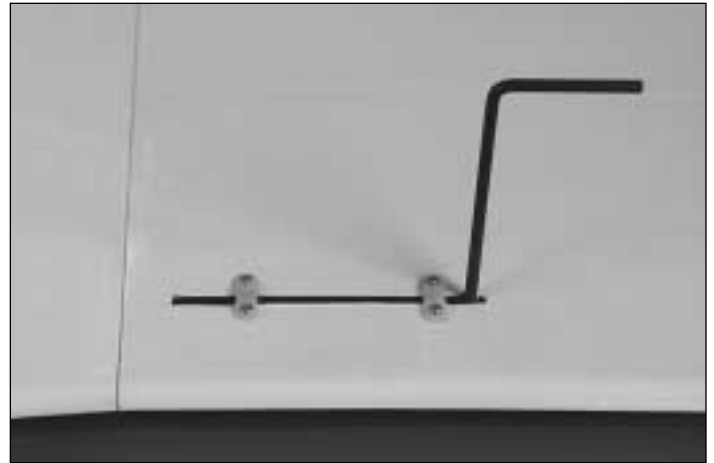

□ □ 2. Locate the nylon **landing gear straps**. Place two straps over the wire as shown. Drill a 1/16" [1.6mm] pilot hole for each hole in the landing gear strap. Install the straps with two #2 x 1/2" [#2 x 13mm] sheet metal screws for each landing gear strap.



□ □ 3. Locate two 5/32" [4mm] **wheel collars**, two 4-40 **set screws** and one of the 2-3/4" foam **wheels**. Install a wheel collar, the wheel and then another wheel collar onto the landing gear wire. Install a set screw into each wheel collar, tightening it to keep the wheel collars in place. When locating the wheel collars be sure to leave enough room for the wheel to spin freely.

□ 4. Repeat these steps for the left wing.

## Mount the Stab and Fin



- ❑ 1. Cut the covering from the slots in the fuse for the stab, fin and guide tubes for the pushrods.

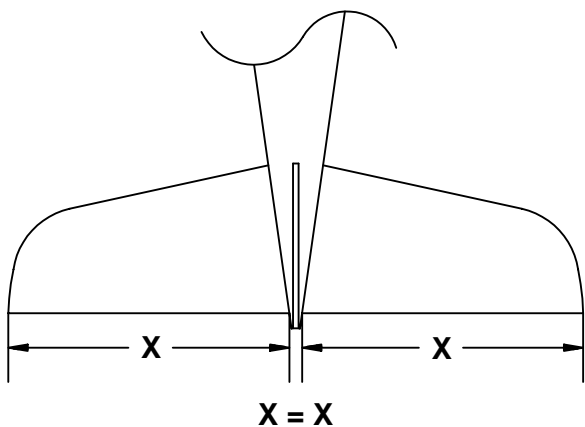

- ❑ 2. Fit the stab into the fuse. Center the trailing edge by taking accurate measurements as shown in  $X = X$  in the sketch.



- ❑ 3. Bolt the wing to the fuse. Place the model in a building stand (such as a Robart Super Stand II, ROBP1402). Stand five to ten feet behind the model and view the stab and wing. If the stab and wing align with each other, proceed to the next step. If the stab and wing do not align, place a weight on the "high" side of the stab to bring it into alignment. If much weight is required, remove the stab and sand the slot in the fuse where the stab fits until the stab aligns with the wing.



- ❑ 4. Insert a T-pin into the top of the fuse centered in the middle stringer at the front of the wing. Tie a small loop in one end of a 42" piece of non-elastic string such as K & S #801 Kevlar thread (K+SR4575). Slip the loop in the string over the T-pin.

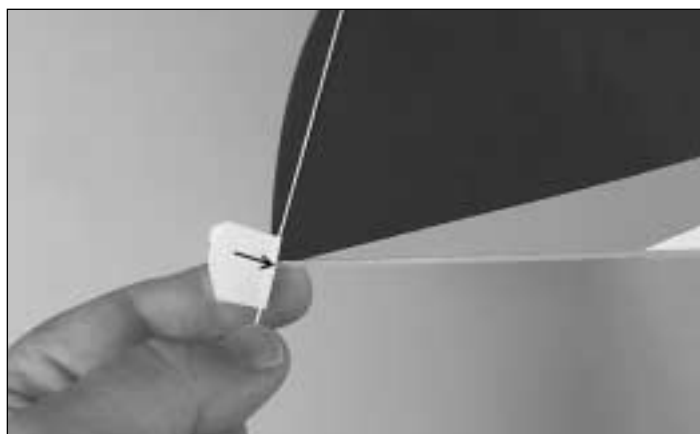

- ❑ 5. Fold a piece of masking tape over the other end of the string and draw an arrow on it. Slide the tape along the string and align the arrow with one end of the stab as shown in the photo. Swing the string over to the same position on the other end of the stab. While keeping the stab centered from side-to-side, adjust the stab and slide the tape along the string until the arrow aligns with both sides. Be certain the stab remains centered from side-to-side during this process.



- ❑ 6. Use a fine-point felt-tip pen such as a Top Flite Panel Line Pen (TOPQ2510) to mark the outline of the fuse onto the top and bottom of the stab.

- ❑ 7. Remove the stab from the fuse. Use a sharp #11 hobby knife or use the **Expert Tip** that follows to cut the covering from the stab along the lines you marked. Use care to cut **only into the covering** and **not** into the wood.



**How to cut covering from balsa.**



Use a Hobbico Hot Knife (HCAR0770) or soldering iron to cut the covering from the stab. The tip of the soldering iron doesn't have to be sharp, but a fine tip does work best. Allow the iron to heat fully. Use a straightedge to guide the soldering iron at a rate that will just melt the covering and not burn into the wood. The hotter the soldering iron, the faster it must travel to melt a fine cut. Peel off the covering.

- ❑ 8. The same as you did for the wing, cut the covering from the hinge slots in the stab and elevators and the fin and rudder. Be sure to clear out the slot with the back edge of your hobby knife. There are three slots in the rudder and in both elevators and two hinge slots in the fin. There is also a hinge slot in the fuse that aligns with the bottom hinge slot in the rudder.

- ❑ 9. Use six more CA hinges from the CA hinge strip. Temporarily join the elevators to the stab with the hinges.

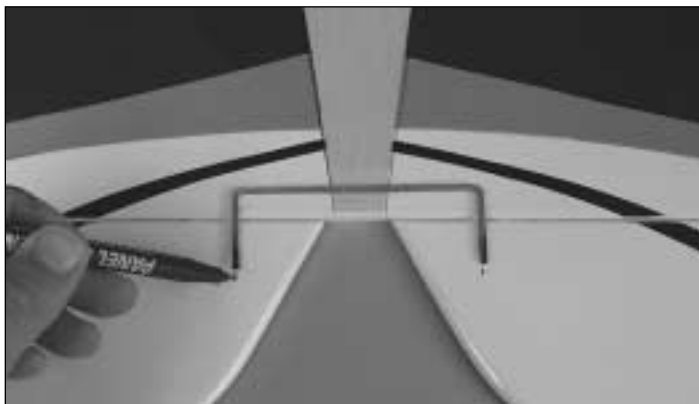

- ❑ 10. Position the **elevator joiner wire**, evenly spaced, over both elevators as shown in the photo. Mark the ends of the joiner wire onto the elevators and extend this mark to the leading edge of the elevators.

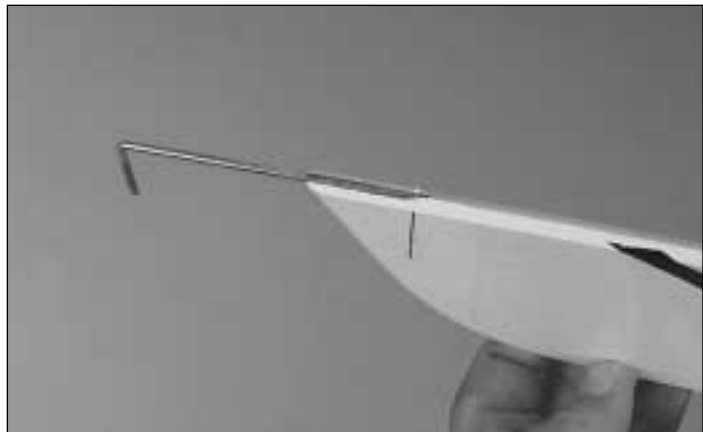
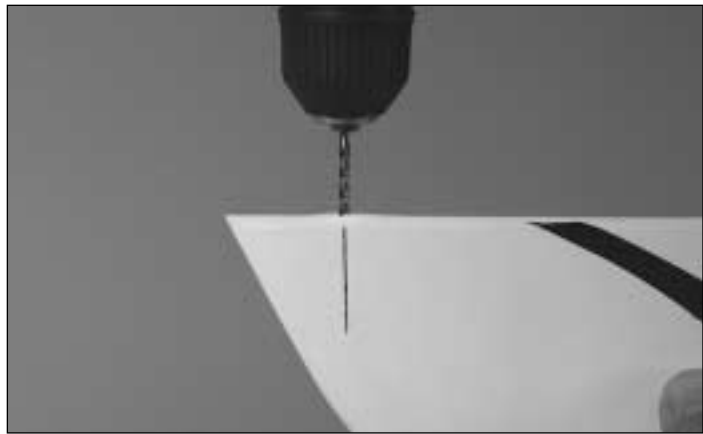

- ❑ 11. Drill a 1/8" hole through the LE of both elevators at the marks you made. Use a Great Planes Groove Tube™ or a 1/8" brass tube sharpened on the end to cut a groove in the LE of the elevators to accommodate the joiner wire. Test fit the elevators to the stab with the joiner wire. "Tweak" the joiner wire if necessary to get both elevators even.

- ❑ 12. Remove the elevators and elevator joiner wire from the stab.

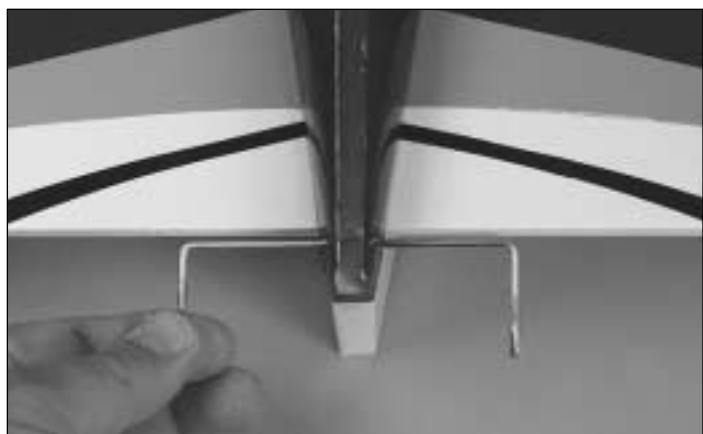

- ❑ 13. Use 30-minute epoxy to glue the stab into the fuse. For the most strength, apply epoxy to both sides of the stab **and** inside the fuse where the stab fits. Slide the stab **and the elevator joiner wire** into position. Wipe away residual epoxy with a tissue dampened with alcohol. If the stab required a weight on one side or the other to align it with the fuse, reposition the weight. Use the pin and string to confirm stab alignment. Allow the epoxy to cure.

❑ 14. **Thoroughly** coat the insides of the holes in the elevators for the joiner wire with 30-minute epoxy. Also coat the ends of the joiner wire that go into the elevators. Join the elevators to the stab and the joiner wire with the hinges. Wipe away excess epoxy before it hardens. The same as you did the ailerons, permanently join the elevators to the stab by gluing in the hinges with thin CA.

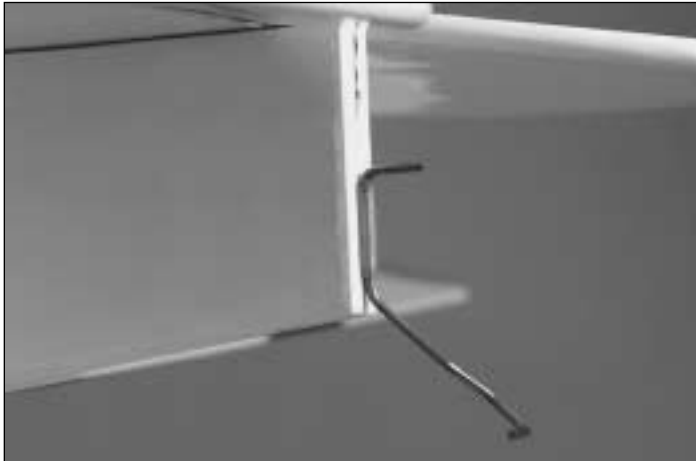

❑ 15. Use a #11 blade or a small razor saw to cut a slot in the aft end of the fuse for the nylon bearing on the tail gear wire. Test fit the tail gear wire into the fuse as shown.



❑ 16. Fit the fin in the fuse. Just the same as you did the stab, mark the outline of the fuse onto the fin, then use a #11 hobby knife or the soldering iron technique to remove the covering from the fin where it slides onto the fuse top. Glue the fin into position with 30-minute epoxy using a builder's square to make certain the fin is vertical. If necessary, pull the fin to one side or the other with masking tape until the fin is perpendicular to the stab.

❑ 17. Apply petroleum jelly to the nylon wheel bearing where the wire passes through. This will prevent the wire from being glued to the bearing. Permanently join the rudder to the fin using 30-minute epoxy to glue the "arm" portion of the tail gear wire into the hole in the rudder. Then use thin CA to glue in the hinges.

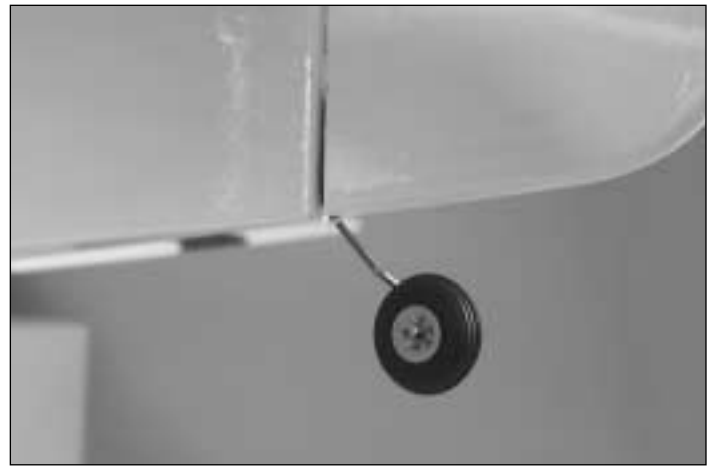

❑ 18. Install the **tailwheel** onto the 3/32" [2.4mm] **tailwheel wire**. Retain the wheel by installing a 4-40 set screw into the 3/32" [2.4mm] wheel collar and then lock the wheel collar in place with the set screw.

### ***Mount the Engine and Fuel Tank***

❑ 1. The engine mounting plate on the Slow Poke Sport .40 ARF was designed to accommodate most brands of .35 to .46 engines. As it is cut now, the mount will hold most brands of .35 engines. If you are using a .40 or .46 engine you will have to cut the mounting plate to accommodate the engine you have chosen to use. Cut the mounting plate to fit your engine.

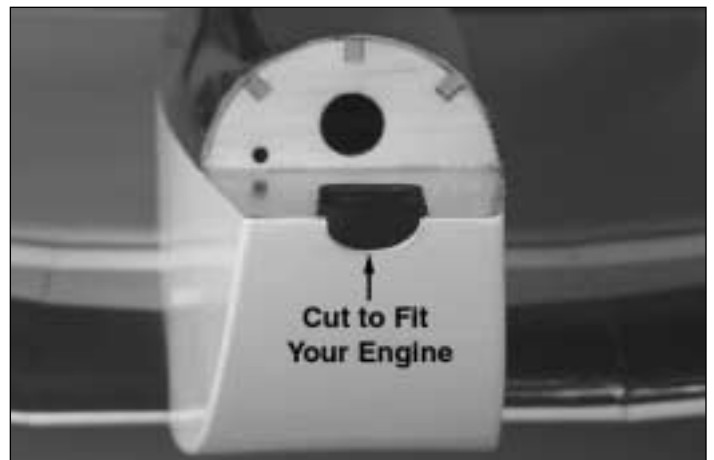

❑ 2. Cut the fuselage to accommodate the front of your engine. A Moto-Tool™ with a rotary drum makes this a pretty easy task.



3. On the bottom of the engine compartment cut away the covering from the hole (this hole can be seen by looking into the front of the fuselage from the top) in the bottom of the fuselage. This hole allows any fuel that may enter the front of the fuselage to drain out.

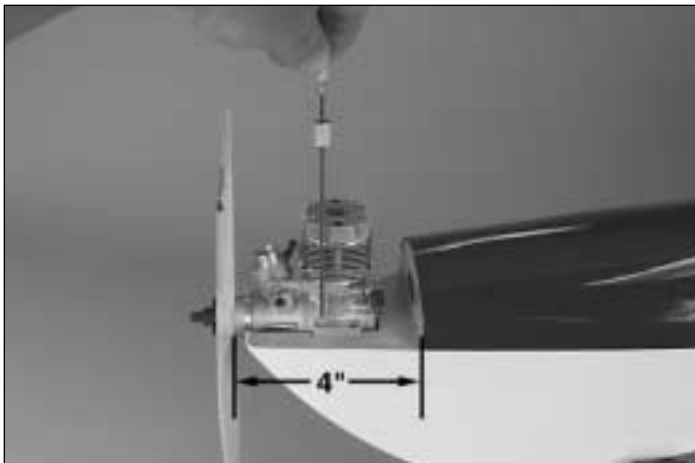

4. Use small clamps or another method to temporarily secure the engine to the engine mounting plate with the front of the engine thrust washer 4" [102mm] from the firewall. Use a Great Planes Dead Center™ Engine Mount Hole Locator (GPMR8130) or another method to mark the engine mount holes onto the engine mounting plate.

5. Drill a 5/32" [4mm] holes on each of the marks you have made.



6. Locate four 6/32 blind nuts. Cut one side flat as shown.

7. On the underside of the engine mounting plate insert the blind nuts into the holes you have drilled. When you position them be sure that the flat side of the blind nut is in line with the edge of the engine mounting plate. This will allow clearance for the side of the engine as it is slid onto the engine mounting plate.

8. Mount the engine to the engine mounting plate with four 6-32 x 1" SHCS (socket-head cap screws), #6 lock washers and #6 flat washers.

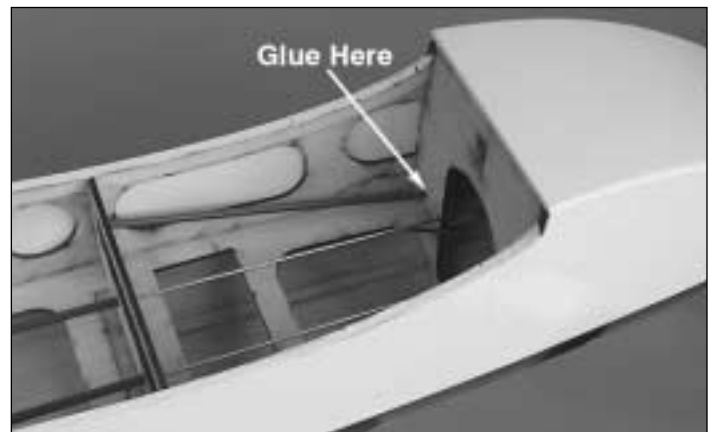

9. Locate the 11-3/4" [298mm] gray plastic tube. Insert it through the hole on the right side of the fuselage and through the pre-drilled hole located on the right side of the former in the engine compartment of the fuselage. Apply a small amount of 5 minute epoxy to the tube to keep it in place. **Note:** If you are installing a 4-cycle engine you may find it necessary to drill a hole in the firewall to accommodate the gray plastic tube in a different location other than the pre-drilled hole in the firewall.

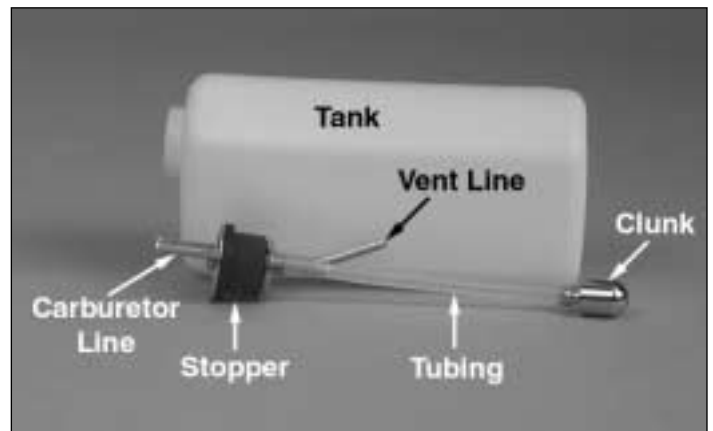

10. Assemble the stopper and tubes as shown in the photo. Insert the completed stopper assembly into the tank. Tighten the screw to expand the stopper, thus sealing the tank. Be certain the fuel line weight (clunk) at the end of the

fuel line inside the tank does not contact the rear of the tank. Otherwise, the line may become stuck during flight and discontinue fuel flow. Remember (or use a felt-tip pen to mark) which tube is the fuel pick-up tube and which tube is the vent (that will be connected to the pressure fitting on the engine muffler).

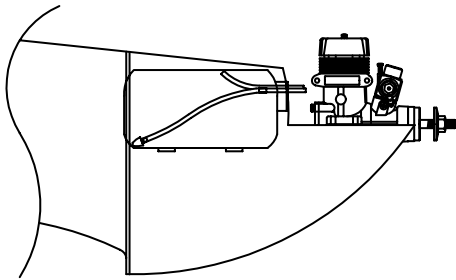

❑ 11. Install the tank in the fuse. Fit the neck through the hole in the firewall. Be certain the vent tube inside the tank is pointing upward.

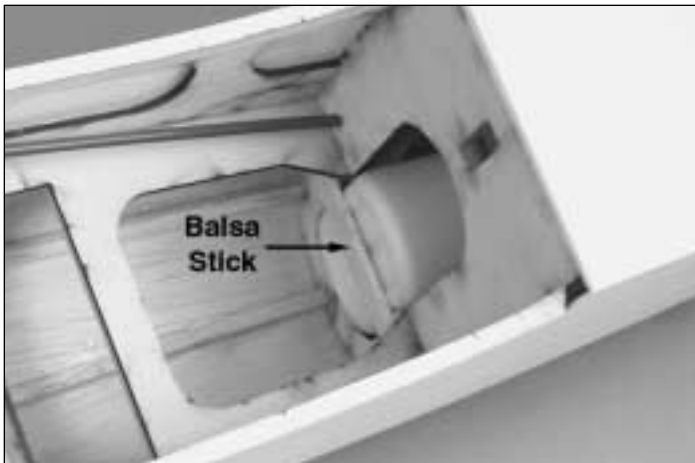

❑ 12. Hold the tank in place on the tank supports by gluing a scrap piece of balsa (not included) across the former.

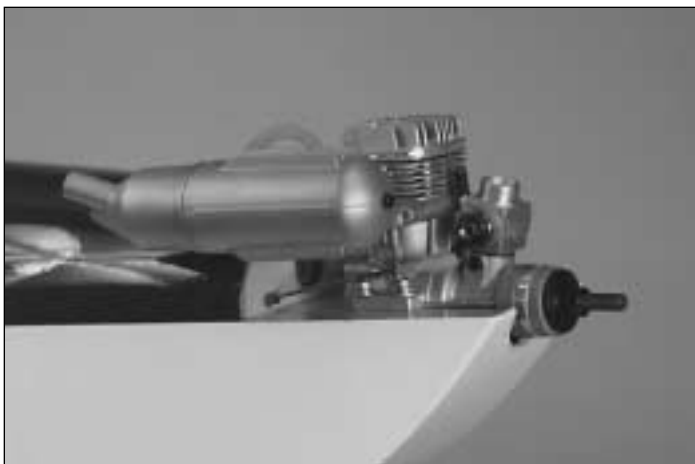

❑ 13. Make the **throttle pushrod** by threading a nylon clevis approximately 25 full turns onto the end of a 12" pushrod. Slide a silicone clevis keeper over the end of the clevis. Insert the end of the wire into the gray plastic tube you previously installed. Next connect the clevis to the throttle arm on the engine.

❑ 14. Install the engine muffler. Install silicone fuel line (not included) from the fuel tank pick up line to the carburetor and from the fuel tank vent line to the muffler.

### Install the Radio

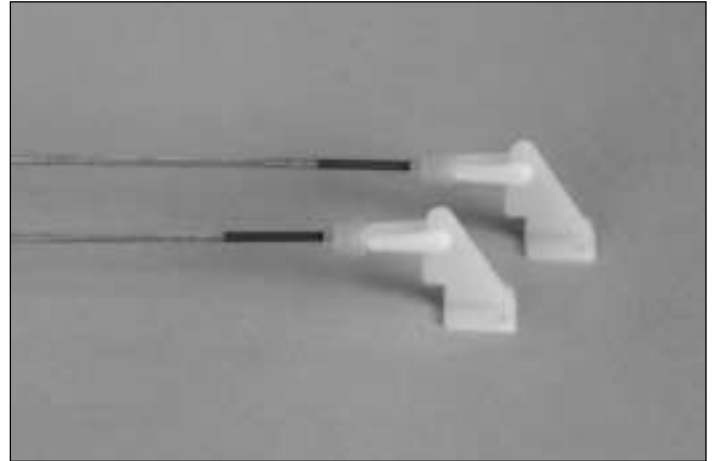

❑ 1. Make the **elevator** and **rudder pushrods** by threading two nylon clevises approximately 25 full turns onto the end of two 36" pushrods. Slide a silicone clevis keeper over the end of the clevis. Connect each clevis to a large nylon control horn.

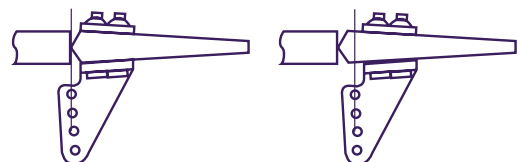
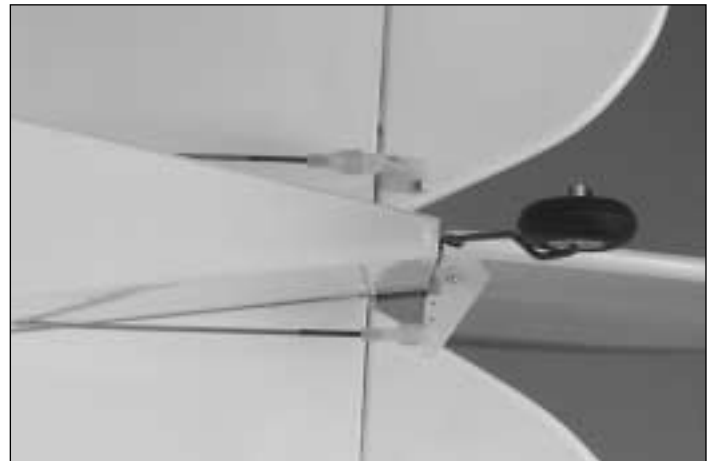

Correct

Incorrect

❑ 2. Slide the pushrods into the guide tubes through the aft end of the fuse. Drill 3/32" holes through the rudder and elevator and mount the horns with 2-56 x 5/8" [2-56 x 15.9mm] screws and the nylon mounting plates on the other side of the control surface. Attach the clevis to the control horn. Slide the silicone clevis keeper over the clevis.

Refer to this photo while mounting the servos.

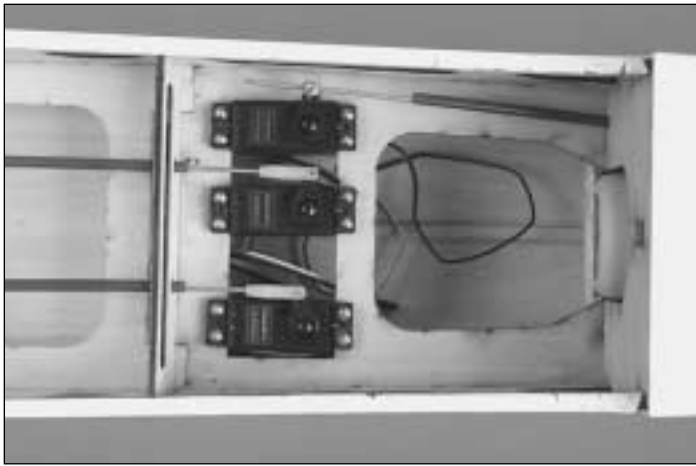

- ❑ 3. Test fit the rudder, elevator and throttle servos in the 1/8" plywood servo tray. Make modifications to the tray if necessary to fit the servos.

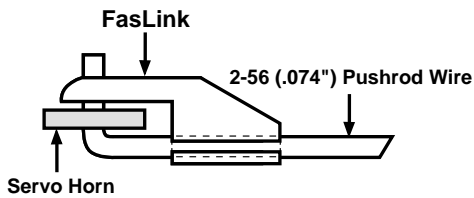

- ❑ 4. Place the servos in the tray. Mount them with the hardware provided with the radio system. Center the servos and position the servo arms as shown in the photo at step #3. Center the elevator and rudder. Bend the elevator and rudder pushrods over the holes in the servo arms. Cut the wires so they can be connected to the servos with a nylon Faslink as shown in the sketch.

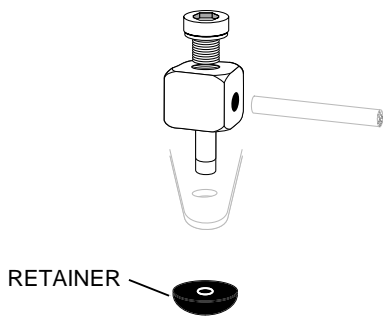

- ❑ 5. Attach the throttle to the servo using the brass **screw lock connector**, **nylon retainer** and **4-40 set screw**. Turn your radio system on. Push the throttle stick to full open. Be sure the carburetor is also fully opened. Tighten the set screw onto the throttle wire.

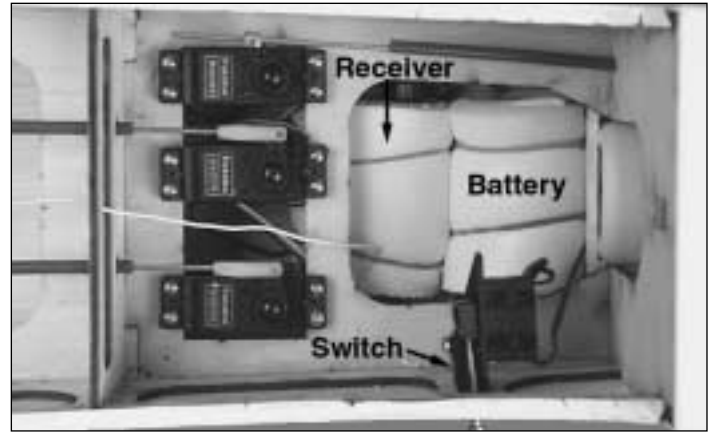

- ❑ 6. Wrap the battery pack and receiver in at least 1/4" of R/C foam rubber and install them in the fuselage. Securely hold the battery pack and receiver in position with a balsa stick glued between the fuse sides (not shown). Simply stuffing the receiver and battery pack in place with additional foam rubber is not a secure method of holding them in place.

- ❑ 7. If you did not previously install a Y-harness to the ailerons, connect a Y-harness (HCAM2500 for Futaba J) to the aileron servo wires in the wing. Secure the connections with heat shrink tubing, tape or clips intended for that purpose.

- ❑ 8. Mount the receiver on/off switch. A Great Planes Switch & Charge Jack Mounting Set (GPMM1000, not included) was used on this model. Be certain it is in a location away from engine exhaust.

- ❑ 9. Make certain all the servo arms are secured to the servos with the screws that came with them and that all the clevises have retainers on them.

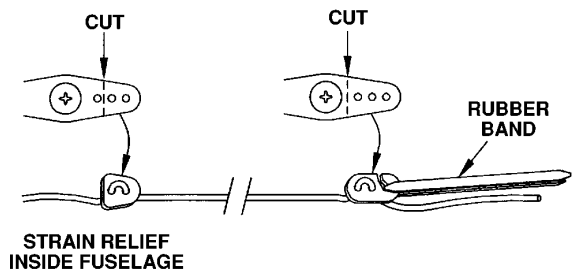

- ❑ 10. Uncoil the receiver antenna and guide it out of the fuselage and connect it to the fin. We drilled a 7/32" [5.6mm]

hole in the bottom of the fuselage just behind the radio compartment and inserted a piece of fuel tubing (this acts as a strain relief) into the hole. Then, we ran the antenna wire out of the inside of the fuselage through the fuel tubing. (The antenna wire should run through an unused servo arm and the arm should be positioned just below the hole you drilled in the fuselage.) Next, we cut an unused servo arm as shown, allowing the antenna wire to be attached to a rubber band. Finally, the rubber band was wrapped around the tailwheel wire.



One of the leading causes of crashes is flying an airplane with its control throws set differently from those recommended in the instructions. The Great Planes AccuThrow (GPMR2405) lets you quickly and easily measure actual throws first, so you can make necessary adjustments before you fly. Large, no-slip rubber feet provide a firm grip on covered surfaces without denting or marring the finish. Spring tension holds AccuThrow's plastic ruler steady by each control surface. Curved to match control motions, the ruler provides exact readings in both standard or metric measurements. Make sure the control surfaces move in the proper direction as illustrated in the following sketch:

## FINAL ASSEMBLY

1. Install the spinner included with the kit and a propeller appropriate for your choice of engine.

### Control Throw Adjustment

By moving the position of the clevis at the control horn toward the outermost hole, you will decrease the amount of throw of the control surface. Moving it toward the control surface will increase the amount of throw. If these adjustments don't accomplish the job, you may need to work with a combination of adjustments by also repositioning the pushrod at the servo end. Moving the pushrod towards the center of the servo horn will decrease the control surface throw, outward will increase it.

### Control Surface Throws

Note: Throws are measured at the widest part of the elevators, rudder and ailerons. We recommend the following control surface throws as a starting point:

These are the recommend control surface throws:

	High Rate	Low Rate
<b>ELEVATOR:</b>	7/16" [11mm] up 7/16" [11mm] down	1/4" [6mm] up 1/4" [6mm] down
<b>RUDDER:</b>	1-1/2" [38mm] right 1-1/2" [38mm] left	1-1/2" [38mm] right 1-1/2" [38mm] left
<b>AILERONS:</b>	1" [25mm] up 1" [25mm] down	3/4" [19mm] up 3/4" [19mm] down

### 4-CHANNEL RADIO SETUP (STANDARD MODE 2)

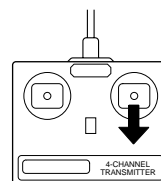

ELEVATOR MOVES UP

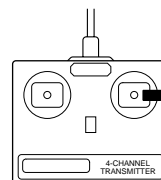

RIGHT AILERON MOVES UP  
LEFT AILERON MOVES DOWN

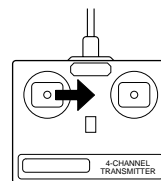

RUDDER MOVES RIGHT

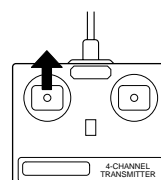

CARBURETOR WIDE OPEN

## BALANCE YOUR MODEL

**Note:** This section is VERY important and must NOT be omitted! A model that is not properly balanced will be unstable and possibly unflyable.



1. The balance point (C.G.) is located 4-5/8" [116mm] back from the leading edge of the wing. Balance your Slow Poke Sport .40 ARF using a Great Planes C.G. Machine Airplane Balancer (GPMR2400) for the most accurate results. This is the point at which your model should balance for your first flights. After initial trim flights and when you become more acquainted with your Slow Poke Sport .40 ARF, you may wish to experiment by shifting the balance up to 3/8" [9.5mm] forward or backward to change its flying characteristics. Moving the balance forward may improve the smoothness and stability, but the model may then require more speed for takeoff and may become more difficult to slow for landing. Moving the balance aft makes the model more agile with a lighter, snappier feel. In any case, please start at the location we recommend. Do not at any time balance your model outside the recommended range.

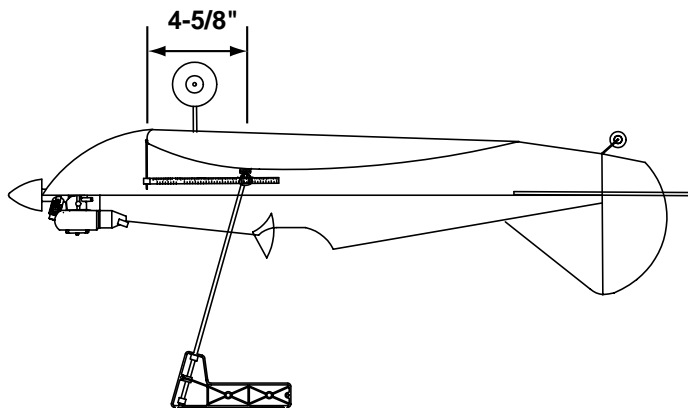

2. With all parts of the model installed (ready to fly) and an empty fuel tank, block up the tail as necessary to level the stab. Lift the model at the desired balance point and observe the tail of the aircraft. If the tail drops, the model is "tail heavy" and you must add weight to the nose to balance the model. If the nose drops, it is "nose heavy" and you must add weight to the tail to balance the model.

**Note:** Nose weight may be easily installed by using a spinner weight. Tail weight may be added by using Great Planes (GPMQ4485) "stick-on" lead weights.

## Balance Your Model Laterally

**IMPORTANT:** Do not confuse this procedure with checking the C.G. or balancing the airplane fore and aft.

Now that you have the basic airplane nearly completed, this is a good time to balance the airplane laterally (side-to-side). Here is how to do it:

1. Make sure the fuel tank is empty.
2. With the wing level, lift the model by the engine propeller shaft and the fin post (this may require two people). Do this several times.
3. If one wing always drops when you lift the model, it means that side is heavy. Balance the airplane by adding weight to the opposite, lighter wing tip.

**Note:** An airplane that has been laterally balanced will track better in loops and other maneuvers.

## PREFLIGHT

At this time check all connections including servo horn screws, clevises, servo cords and extensions.

## Charge the Batteries

Follow the battery charging procedures in your radio instruction manual. You should always charge your transmitter and receiver batteries the night before you go flying and at other times as recommended by the radio manufacturer.

## Balance the Propeller

Carefully balance your propellers before flying. An unbalanced prop is the single most significant cause of vibration. Not only may engine mounting screws vibrate out, possibly with disastrous effect, but vibration may also damage your radio receiver and battery. Vibration may cause your fuel to foam, which will, in turn, cause your engine to run lean or quit.

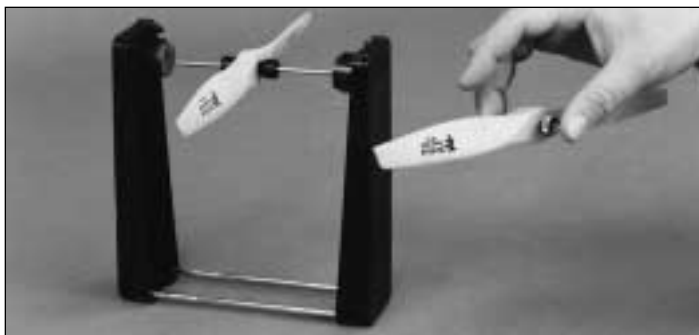

We use a Top Flite Precision Magnetic Prop Balancer (TOPQ5700) in the workshop and keep a Great Planes Fingertip Balancer (GPMQ5000) in our flight box.

### ***Find a Safe Place to Fly***

We strongly suggest that the best place to fly is an AMA chartered club field. Ask the AMA or your local hobby shop dealer if there is a club in your area and join. Club fields are set up for R/C flying and that makes your outing safer and more enjoyable. The AMA address and telephone number are in the front of this manual. If a club and flying site are not available, find a large, grassy area at least 6 miles away from houses, buildings and streets and any other R/C radio operation like R/C boats and R/C cars. A schoolyard may look inviting but is too close to people, power lines and possible radio interference.

### ***Ground Check the Model***

Inspect your radio installation and confirm that all the control surfaces respond correctly to the transmitter inputs. The engine operation must also be checked by confirming that the engine idles reliably, transitions smoothly and rapidly to full power and maintains full power, indefinitely. The engine must be “broken-in” on the ground by running it for at least two tanks of fuel. Follow the engine manufacturer's recommendations for break-in. Make sure that all screws remain tight, that the hinges are secure and that the prop is on tight.

### ***Range Check Your Radio***

Whenever you go to the flying field, check the operational range of the radio before the first flight of the day. First, make sure no one else is on your frequency (channel). With your transmitter and receiver on, you should be able to walk at least 100 feet away from the model and still have control. While you work the controls, have a helper stand by your model and tell you what the control surfaces are doing. Repeat this test with the engine running at various speeds with a helper holding the model. If the control surfaces are not always responding correctly, do not fly! Find and correct

the problem first. Look for loose servo connections or corrosion, loose bolts that may cause vibration, a defective on/off switch, low battery voltage or a defective receiver battery, a damaged receiver antenna, or a receiver crystal that may have been damaged from a previous crash.

## ***ENGINE SAFETY PRECAUTIONS***

**Note:** Failure to follow these safety precautions may result in severe injury to yourself and others.

Keep all engine fuel in a safe place, away from high heat, sparks or flames, as fuel is very flammable. Do not smoke near the engine or fuel; and remember that the engine exhaust gives off a great deal of deadly carbon monoxide. Do not run the engine in a closed room or garage.

Get help from an experienced pilot when learning to operate engines.

Use safety glasses when starting or running engines. Do not run the engine in an area of loose gravel or sand; the propeller may throw such material in your face or eyes.

Keep your face and body as well as all spectators away from the plane of rotation of the propeller as you start and run the engine.

Keep these items away from the prop: loose clothing, shirt sleeves, ties, scarfs, long hair or loose objects such as pencils or screwdrivers that may fall out of shirt or jacket pockets into the prop.

Use a “chicken stick” or electric starter to start the engine. Do not use your fingers to flip the propeller. Make certain the glow plug clip or connector is secure so that it will not pop off or otherwise get into the running propeller.

Make all engine adjustments from behind the rotating propeller.

The engine gets hot! Do not touch it during or right after operation. Make sure fuel lines are in good condition so fuel will not leak onto a hot engine, causing a fire.

To stop a glow engine, cut off the fuel supply by closing off the fuel line or following the engine manufacturer's recommendations. Do not use hands, fingers or any other body part to try to stop the engine. Do not throw anything into the propeller of a running engine.

## **AMA SAFETY CODE (EXCERPT)**

Read and abide by the following Academy of Model Aeronautics Official Safety Code:

### **General**

1. I will not fly my model aircraft in sanctioned events, air shows, or model flying demonstrations until it has been proven to be airworthy by having been previously successfully flight tested.
2. I will not fly my model aircraft higher than approximately 400 feet within 3 miles of an airport without notifying the airport operator. I will give right of way to and avoid flying in the proximity of full-scale aircraft. Where necessary an observer shall be used to supervise flying to avoid having models fly in the proximity of full-scale aircraft.
3. Where established, I will abide by the safety rules for the flying site I use and I will not willfully and deliberately fly my models in a careless, reckless and/or dangerous manner.
4. I will not fly my model unless it is identified with my name and address or AMA number, on or in the model.
5. I will not operate models with pyrotechnics (any device that explodes, burns, or propels a projectile or any kind).

### **Radio Control**

1. I will have completed a successful radio equipment ground check before the first flight of a new or repaired model airplane.
2. I will not fly my model aircraft in the presence of spectators until I become a qualified flier, unless assisted by an experienced helper.
3. I will perform my initial turn after takeoff away from the pit or spectator areas and I will not thereafter fly over pit or spectator areas, unless beyond my control.
4. I will operate my model using only radio control frequencies currently allowed by the Federal Communications Commission.

## **FLYING**

The Slow Poke Sport .40 ARF is a fun and enjoyable plane to fly. It is very predictable when balanced at the recommended C.G. and the control throws are set at the low rate recommendation. Set up this way you will find that it performs most mild aerobatic maneuvers with ease. Move the C.G. back and step up to the high rate control throws and you will have a very responsive fun flying model!

### **Takeoff**

The Slow Poke Sport .40 ARF has no bad ground handling characteristics. Simply line up on the runway, advance the throttle slowly, make steering corrections as needed with the rudder and you will be airborne in about 50 feet.

### **Flying**

Once airborne you will find that the Slow Poke Sport .40 ARF performs slow flight maneuvers as easily as it performs at faster speeds. Tight loops, large loops, slow rolls, fast rolls, inverted flight are all easily done with the Slow Poke Sport .40 ARF. You will find slow flight especially fun as the large wing really allows it to slow nicely!

#### **CAUTION (THIS APPLIES TO ALL R/C AIRPLANES):**

If, while flying, you notice any unusual sounds, such as a low-pitched "buzz," this may be an indication of control surface "flutter." Because flutter can quickly destroy components of your airplane, any time you detect flutter you must immediately cut the throttle and land the airplane! Check all servo grommets for deterioration (this will indicate which surface fluttered) and make sure all pushrod linkages are slop-free. If it fluttered once, it will probably flutter again under similar circumstances unless you can eliminate the slop or flexing in the linkages. Here are some things which can result in flutter: Excessive hinge gap; Not mounting control horns solidly; Sloppy fit of clevis pin in horn; Elasticity present in flexible plastic pushrods; Side-play of pushrod in guide tube caused by tight bends; Sloppy fit of Z-bend in servo arm; Insufficient glue used when gluing in the elevator joiner wire or aileron torque rod; Excessive "play" or "backlash" in servo gears; and Insecure servo mounting.

### **Landing**

When it comes time to land the Slow Poke Sport .40 ARF, you will find it is as predictable to land as it was to fly. Simply line it up on the runway and slowly decrease the speed. When you are over the runway, drop the throttle and flare to a three point landing!

Have a ball! But always stay in control and fly in a safe manner.